



# SA380TX

USER GUIDE ISSUE 1.4

## Version control

| Version      | Date                     | Amendments  |
|--------------|--------------------------|---|
| 1.0<br>DRAFT | 17 Jul 2009              | Initial draft adapted from SA380 manual v1.8  |
| 1.2          | 5 <sup>th</sup> May 2010 | Final Draft   |
| 1.3          | 3 <sup>rd</sup> Oct 2011 | Incorporates EbiTrack set-up  |
| 1.4          | 1 <sup>st</sup> May 2012 | Updated Isolation specification and other minor corrections.<br>Revised Capture Set-Up and Data Viewing |
|              |                          |   |
|              |                          |   |
|              |                          |   |
|              |                          |   |

© MPEC Ltd. All rights reserved.  
No part of this publication may be copied without the prior consent of MPEC.

EbiTrack® is a registered trademark of Bombardier Transportation UK Ltd.

[www.mpec.co.uk](http://www.mpec.co.uk)

# Contents

|   |           |
|---|-----------|
| <b>Hardware</b> .....                                 | <b>5</b>  |
| Block diagram and isolation policy .....              | 6         |
| Power supply .....                                    | 7         |
| Digital inputs .....                                  | 8         |
| Analogue cards.....                                   | 9         |
| 4-20mA analogue input card.....                       | 10        |
| 30V dc input card.....                                | 11        |
| <br>  |           |
| <b>Applications</b> .....                             | <b>12</b> |
| Important general considerations .....                | 12        |
| SIL 0 software.....                                   | 12        |
| Current measurements .....                            | 13        |
| Voltage measurements.....                             | 14        |
| Trackwork and point machines .....                    | 15        |
| Other measurements .....                              | 16        |
| <br>  |           |
| <b>Local configuration</b> .....                      | <b>17</b> |
| Digital inputs .....                                  | 17        |
| Analogue inputs .....                                 | 18        |
| Acquisition – Acquire on change .....                 | 20        |
| Acquisition – Captures.....                           | 23        |
| <br>  |           |
| <b>Remote configuration</b> .....                     | <b>30</b> |
| Examples.....   | 30        |
| Captures (points).....                                | 31        |
| Acquire-on-change (track circuits).....               | 32        |
| Getting configuration from the logger .....           | 33        |
| <br>  |           |
| <b>Local access</b> .....                             | <b>34</b> |
| How to view stored data .....                         | 35        |
| How to change an external USB disk .....              | 37        |
| How to set the system date and time .....             | 39        |
| How to change the IP address .....                    | 40        |
| How to set the local pass code .....                  | 41        |
| How to shut the logger down safely.....               | 42        |
| Hard reset shutdown.....                              | 44        |
| <br>  |           |
| <b>Network access</b> .....                           | <b>45</b> |
| Direct cable connection .....                         | 45        |
| Internet / intranet.....                              | 45        |
| Dial-up .....   | 46        |
| <br>  |           |
| <b>Troubleshooting direct cable connections</b> ..... | <b>51</b> |
| Some notes about IP settings.....                     | 51        |
| Checking the network connection.....                  | 52        |

|   |           |
|---|-----------|
| <b>EbiTrack® Monitoring .....</b>             | <b>54</b> |
| Wiring up EbiTrack Units for Monitoring ..... | 54        |
| Setting Up a new EbiTrack Unit.....           | 54        |
| Removing an Existing EbiTrack Unit .....      | 57        |
| Viewing Data on the Touch Screen .....        | 58        |
| Viewing Data Remotely .....                   | 60        |
| <br>  |           |
| <b>Specifications.....</b>                    | <b>61</b> |
| MIMOSA parameter offsets .....                | 61        |
| Technical specifications.....                 | 62        |

# Hardware

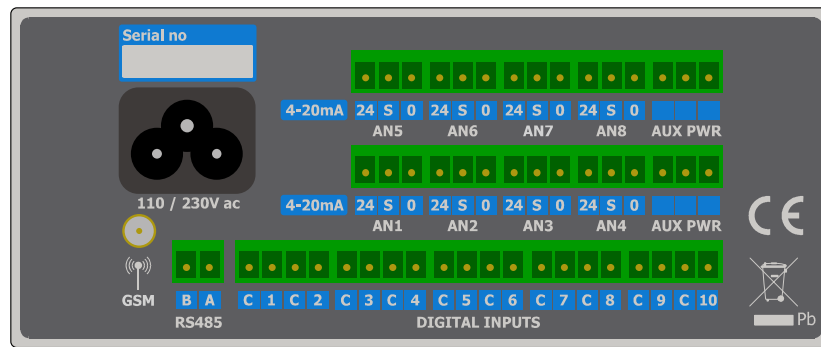

The basic TX unit includes 10 digital inputs, RS485 and a GSM modem.

Up to two expansion cards can be added; these cards may either add an additional 4 analogue or 8 digital inputs.

| Configuration                                | Analogue Inputs | Digital Inputs |
|--|-----------------|----------------|
| Base Unit (No Cards)                         | 0               | 10             |
| Base Unit + 1 Digital Card                   | 0               | 18             |
| Base Unit + 2 Digital Cards                  | 0               | 26             |
| Base Unit + 1 Analogue Cards                 | 4               | 10             |
| Base Unit + 2 Analogue Cards                 | 8               | 10             |
| Base Unit + 1 Analogue Card + 1 Digital Card | 4               | 18             |

### Block diagram and isolation policy

All of the green lines in the diagram below denote an isolation barrier. Every block of the TX shown is isolated from every other block and from the case. All of the individual analogue inputs are isolated from each other and from the auxiliary power supplies. Isolation barriers are to a minimum of 10M Ohms at 1,000V DC.

The thick green lines denote the two analogue cards which may be fitted.

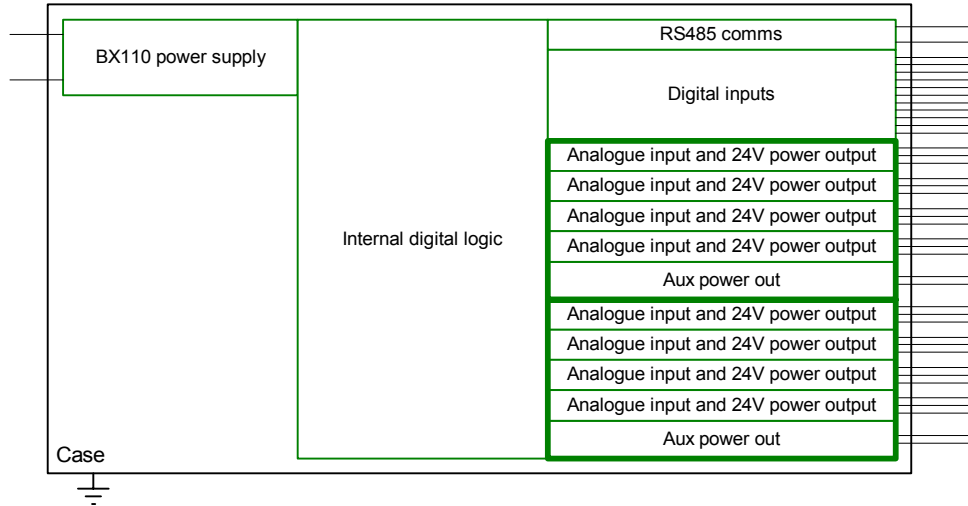

## Power supply

The "universal input" power supply accepts any voltage from 85 to 264V ac. A suggested connection is shown below.

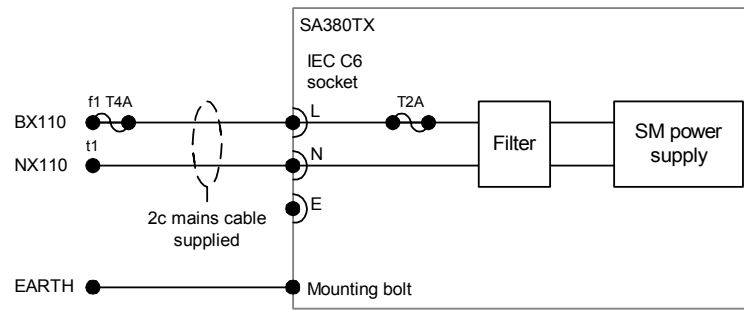

The power supply is internally isolated from earth and the rest of the SA380TX. Power can therefore be taken directly from the signalling 110V supply and no additional isolating transformer is required.

The earth pin of the IEC C6 socket is not connected internally. The unit must be earthed through its connection to the equipment racking.

**If there is doubt over whether the equipment racking provides a suitable earth, or the unit is to be temporarily powered from the domestic mains then a separate earth wire can be run to the SA380TX mounting bolt and attached with an M4 ring crimp and shakeproof washer.**

An internal 2A slow-blow fuse is provided. The external fuse must also be a minimum of 2A slow-blow (often marked T2A). Slow blow is required because of the inrush current of the power supply at startup.

### Power consumption and external equipment

Power consumption of the unit is between 2-10W. If the unit is having to supply external equipment, for instance current clamps or network routers, then power consumption will rise accordingly. Maximum rated consumption is 40W. At 110V, this is 0.36A.

### Internal UPS

An internal hot standby UPS is fitted with 7.2Wh of backup. The backup time will vary from a few minutes to an hour or so depending on external equipment.

## Digital inputs

Ten digital inputs are provided to monitor spare contacts of signalling relays. These inputs are connected as follows:

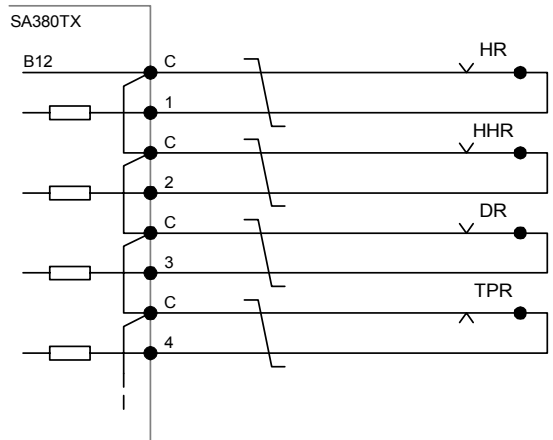

All of the terminals marked “C” are connected together internally. This allows easy wiring to signalling relays using twisted pair cable, as specified in railway standards.

Internal resistors limit the sense current to a few milliamps at 12V.

The digital inputs are fully isolated to a minimum of 10M Ohm at 1,000V DC. This isolation ensures that the inputs are fully separate from earth, the logger’s internal logic and the analogue inputs.

Digital inputs must never be connected into a live circuit (eg across a contact that is already in use by the signalling system). They must only ever be connected to spare relay contacts.

**Note that extra care must be taken when monitoring geographical type relay interlockings, as there are internal connections within the relay sets which are not obvious just from the plugboard positions.**

**We recommend that full signal works testing procedures are used for geographical interlockings, not just Instrumentation Engineer. Also the original interlocking diagrams should be updated – if overlay diagrams are used, there is a risk if other persons change the interlocking circuitry in future.**

These inputs are for use with volt-free relay contacts only. Do not apply voltages to these inputs.

## Analogue cards

Two types of analogue card are available.

### 4-20mA inputs



This is the card shown in the drawing of the back panel on page 5. It has four isolated channels which are capable of powering 4-20mA current clamps. The terminals are:

24: 24V out  
 S: Signal input  
 0: 0V

The input impedance between S and 0 terminals is 200Ω.  
 The maximum output power of the 24V sensor power feed is 2W, or 83mA, per analogue input.

### 30V dc inputs



This type of card simply has four inputs that are capable of measuring 0-30V. The input impedance between S and 0 terminals is 172kΩ.

### Auxiliary power out

Each card can be factory fitted with an auxiliary power output on request. For instance a +12V output could be used to power an Ethernet router or a fibre-ethernet converter.

As another example, adding a power output to the 30V card allows it to be used with sensors that require a ±15V power supply.



### Note that:

**None of the analogue cards must ever be connected directly to any signalling supplies or circuits.**

**This includes (but is not limited to) B24, B50, BX110, track circuits and signalling line circuits.**

## 4-20mA analogue input card

This is the most common type of card. Many types of external sensor are available with a 4-20mA output, including current clamps, temperature sensors, pressure sensors and voltage transducers.

The simplest 4-20mA sensors only have two connections and take their power entirely from the loop. Others have three or four wires. The four wire types use a separate signal and power ground to avoid interference between the power supply and measurement currents.

Example wiring to the different types is shown below:

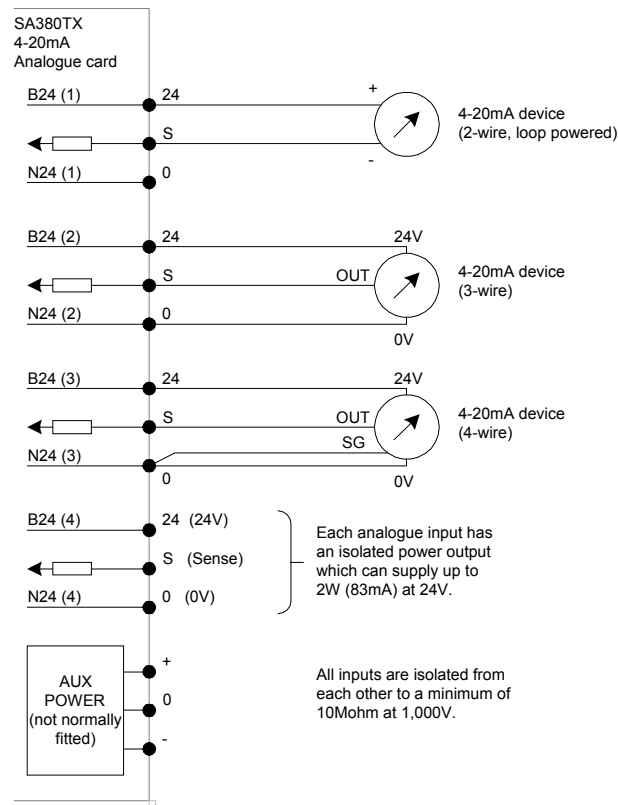

## 30V dc input card

Where an external voltage is being measured, the voltage is simply applied between the S and 0 terminal.

### Use with $\pm 15V$ sensors

Where  $\pm 15V$  sensors are required, an auxiliary power supply can be factory fitted to the card on request.

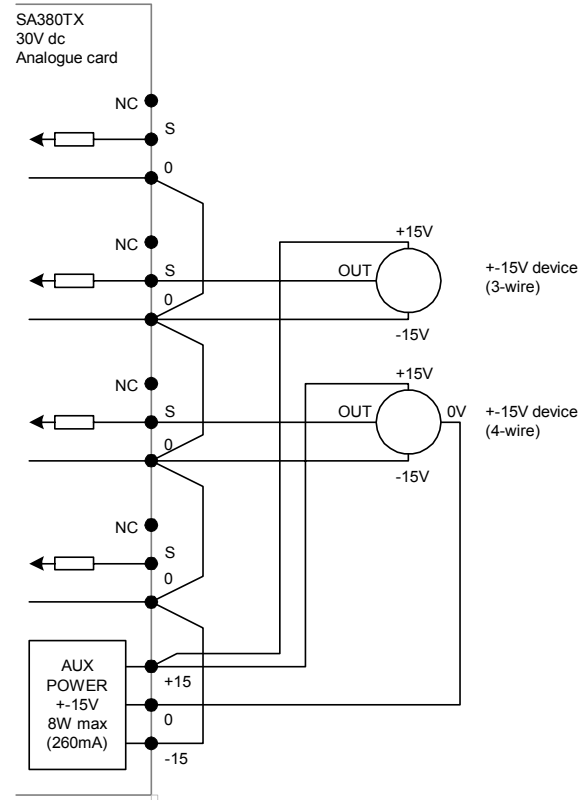

External looping is used to connect the  $-15V$  from the supply to the  $0V$  terminal of each analogue input.

Note that this external looping means that the individual analogue inputs are now connected to each other. They will still have isolation from earth and the rest of the SA380TX unit, but the inter-channel isolation is no longer effective because it has been bridged outside the unit.

## Applications

### Important general considerations

Great care must be taken when adding datalogging to railway signalling systems. The most serious hazard to be considered is the possibility of feeding out a voltage and current that is sufficient to falsely energise a railway signalling relay. The second most serious is accidentally providing an electrical path through a logger from one part of the signalling system to another, or to earth.

An example would be a connection to monitor rail temperature. If the sensor used is not isolated, and the datalogger is also not isolated, the rail will be connected directly to either earth or in the worst case to other parts of the signalling system. This could result in false feeding of the track circuit. This is an extremely dangerous situation.

The SA380TX has been designed from the start with this in mind. Each analogue input and its power supply is individually isolated. However, even this does not mean that it can be indiscriminately connected to any signalling circuit. The chance of isolation failure, while extremely low, must still be considered as a possibility.

**Analogue and digital inputs of the SA380TX must never be directly connected to**

- **track circuit tails**
- **rails**
- **BX110/B50/B24 power supplies**
- **any other live signalling circuits**

The following sections consider these applications in more detail. Restrictions are laid out in each section which **must absolutely be followed**. The key point to be borne in mind by the design engineer at all times is:

**Does the information that is being gained from monitoring this item justify the risk of making the connection?**

### SIL 0 software

Software in this product is designed to SIL 0. It is not a safety critical system and data from an SA380TX must never be used to make safety related decisions.

## Current measurements

Possible applications

- Points motor current
- Track circuit current

Up to 8 currents may be monitored by a single SA380TX.

The following diagram shows two 4-20mA loop powered current clamps connected to two inputs on an analogue card

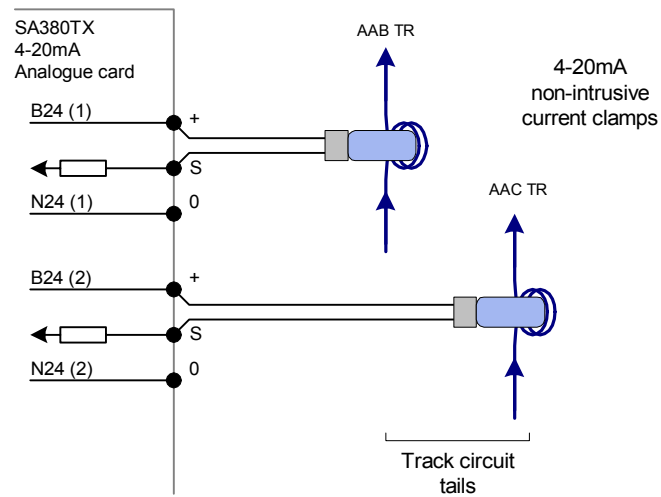

Recommended transducers:

| Measurement type     | Current clamp             | Rating   | No of turns |
|----------------------|---------------------------|----------|-------------|
| DC track circuits    | Rowe Hankins NIC361-6A    | 600mA DC | 1           |
| AC track circuits    | Northern Design XD-I420-1 | 5A AC    | 5           |
| Points motor current | LEM PointSenz PCM20P      | 20A DC   | 1           |

Other types can be used provided that they meet the following requirement:

- **The current transducer must be non-intrusive, ie there must be no direct electrical connection between the track circuit / motor current wire and the transducer itself. It may of either solid core or split core type and must maintain isolation of 4M Ohms at 250V even in the case of the wire chafing and making direct connection with the housing of the transducer.**

## Voltage measurements

Possible applications

- Points motor voltage
- BX110
- B50
- B24

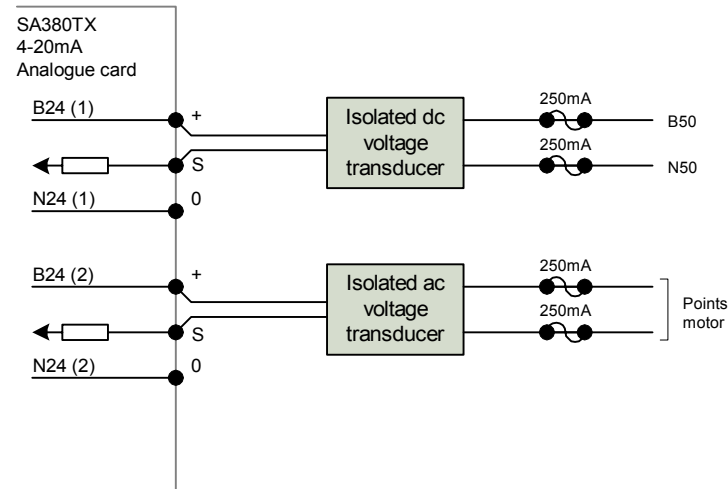

- **250mA fuses must be inserted in each leg between the voltage being monitored and the transducer.**

Note that B50/B24 is usually full wave rectified unsmoothed, so the peak voltage is actually  $50 \times 1.41 = 70V$ , and  $24 \times 1.41 = 34V$ .

Recommended transducers:

| Measurement type               | Transducer          | Rating |
|--------------------------------|---------------------|--------|
| AC points motor voltage, BX110 | Omega DRA-ACT-2V-1  | 150Vac |
| B50, B24                       | Omega CCT-01-0/100V | 100Vdc |
| DC points motor voltage        | Omega CCT-01-0/650V | 650Vdc |

Other types can be used provided that they meet the following requirement:

- **The voltage transducer must contain 3-way isolation to a minimum of 4M Ohms at 250V between input, output and housing.**

## Trackwork and point machines

Possible applications:

- Rail temperature
- Rail vibration
- Points load pin
- Clamp lock power pack monitoring
- Points position monitoring

Special care must be taken when attaching sensors to rails, pointwork, point machines or anything electrically connected to them.

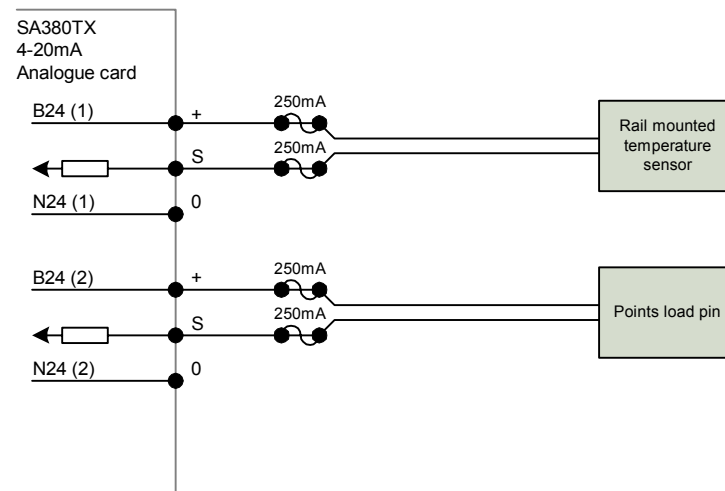

Sensor requirements:

- **Each sensor must have electrical isolation between the 4-20mA output and the trackwork to a minimum of 4M Ohms at 250V.**
- **250mA fuses must be provided in each leg of the current loop.**
- **Only Network Rail approved points load pins may be used.**
- **When monitoring the pressure in clamp lock power packs, only pressure sensors approved by the manufacturer of the power pack must be used.**
- **Where sensors are attached to both rails, a risk assessment must be carried out to ensure that there is no risk of a track circuit being false fed**

## Other measurements

The 4-20mA analogue input card can be used with many other transducers, including temperature, pressure etc.

| <b>Parameter</b> | <b>Suggested 4-20mA device</b>  |
|------------------|---|
| Temperature      | Phoenix Contact MINI MCR-SL-TC-UI(-NC)  |
| Strain / force   | Strainstall provide a wide range of sensors for measuring force in many different situations. |
| Flow             | Omega FMG203-NPT  |
| Wind speed       | Vector Instruments (4-20mA special order)   |

## Local configuration

All configuration of the logger can be carried out using the touchscreen display. For ease of use, a USB keyboard can be plugged in to the port on the front of the logger. This is highly recommended – it can be time consuming typing channel names in on the touchscreen.

To set up the logger, first the individual channels are configured, then the acquisition.

The *inputs* config tells the logger what is connected to each channel. Once this is set, the logger can output the value that is being monitored in calibrated engineering units. For instance, for points motor current, the logger would output a value in the range of 0-20A.

The *acquisition* config tells the logger what to log and when.

### Digital inputs

Setup of digital inputs is straightforward. The only information needed is channel name and whether the input is connected to a front or back contact of a relay (front = normally open, back = normally closed).

Navigate to:

[Menu..Configuration..\[enter passcode\]..Digital](#)

The following dialog is displayed:

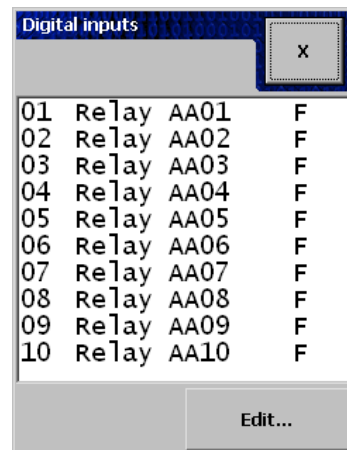

“F” means front contact. Selecting one of the channels and pressing “edit” allows the name and contact type to be changed.

## Analogue inputs

First navigate to the analogue inputs dialog.

[Menu..Configuration..\[enter passcode\]..Analogue](#)

The following dialog is displayed:

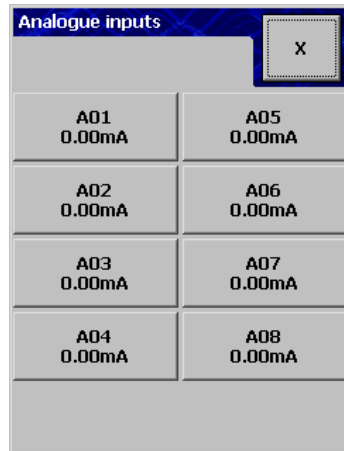

The values shown on the buttons are updated in real time. By default, the sensor type is set to "no sensor", and the actual milliamp value at the 4-20mA input is shown.

Press one of the buttons to edit the channel. The name of the channel can be changed, and the sensor type.

When naming the channels, it is suggested that the following conventions are used:

|         |   |
|---------|---|
| Force   | F |
| Current | I |
| Points  | W |
| Track   | T |

For instance, the motor current of 786 points would be given a name of "786 WI", and 384 track current would be called "384 TI"

### Sensor type

The TX is preconfigured with calibration settings for several sensor types. (Further sensor types can be added by pressing the “New” button and following the instructions.)

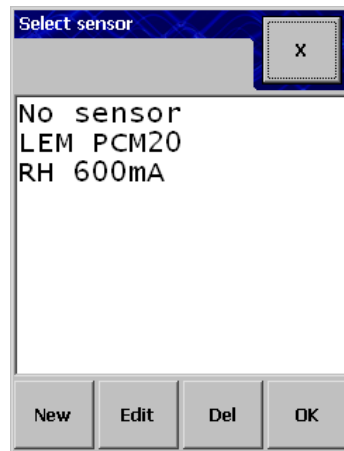

Selecting LEM PCM20 and pressing “OK” then “Save” returns to the analogue inputs screen:



The input is showing  $-5.0A$  because there is no actual sensor connected to the input. When the sensor is connected, it will present  $4mA$  at the input, which corresponds to a motor current of  $0A$ , and the logger will display  $0.0A$ .

## Acquisition – Acquire on change

### Background

The principle of acquire on change is simple. A sample is acquired when the measured value changes by more than a certain amount. If there is no change, there is no sample acquired.

Consider the following waveform. The acquired samples are shown as dots.

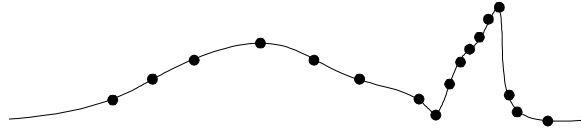

The waveform first changes at a fairly leisurely pace, then there is a spike. Each time the input changes by a given percentage, a sample is acquired. It can be seen that more data points are acquired around the spike.

Acquire-on-change is an excellent match for many railway applications. Where there are long periods without much change, very little data is acquired. Where there is more detail in the waveform, more points are acquired.

After the data has been acquired it is possible to go back and just “join the dots” and we have an accurate representation of the entire waveform, with the minimum amount of data logged.

### Batching

It would be inefficient to save each sample (or push each sample to the server) individually. This is particularly relevant when the waveform is changing quickly.

At present it takes approximately ten seconds to send a message to the server over GPRS. If the waveform is changing quickly, the logger can be acquiring 100 samples per second. It is clearly not possible or desirable to send each sample individually.

Two parameters are used to control the batching. If the waveform is changing, the logger will wait until it stops, then a few seconds later will batch up the samples it has acquired during the change and save/send them. This number of seconds is settable.

However if the waveform is continuously changing, albeit slowly, then there needs to be a backup plan to ensure that samples still get saved/sent. Hence there is a second parameter which allows the user to set a maximum number of samples in the buffer.

### Setting up acquire-on-change

Navigate to:

[Menu..Configuration..Acquire-on-change](#)



By default, all of the acquire-on-change is turned off. To configure it on a channel, press the appropriate button on this dialog.

The following is then displayed:

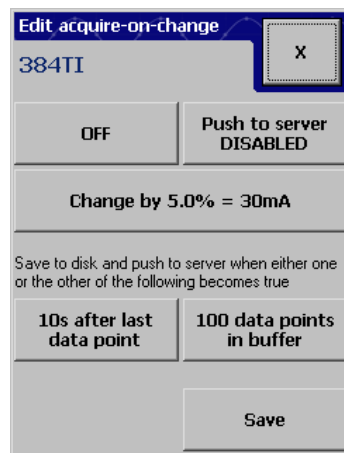

Acquire-on-change is set as a percentage of full scale deflection (the maximum measured value for a channel). In this case the channel is connected to a 0-600mA current clamp. Hence 5% of this is 30mA.

All parameters can be set by pressing the appropriate buttons on this dialog.

**Remote configuration**

Pressing the button marked "OFF" toggles the acquire-on-change to "ON"

Pressing "Save" stores the settings and activates the acquire-on-change for this channel.



384TI is now shown bold, with the acquire-on-change thresholds underneath.

## Acquisition – Captures

In this mode the SA380TX behaves like an oscilloscope.

The principle is that a start trigger and an end trigger are set, and the TX records data between these two points. The data is recorded to disk in a file, and sent to a central server as well if available.

Triggering and capture is very flexible; the TX can trigger on any digital channel or analogue level, and can log data from any of the analogue channels. It can also be set to log data before and after the start trigger and end trigger events (this is called pretrigger and posttrigger).

Up to three analogue channels can be logged in each capture.

Up to 16 captures can be set up. Captures all run completely independently of each other and can run simultaneously. They can also be associated together or “grouped”, for example the Normal to Reverse capture from a set of points may be “grouped” with the Reverse to Normal capture from the same points.

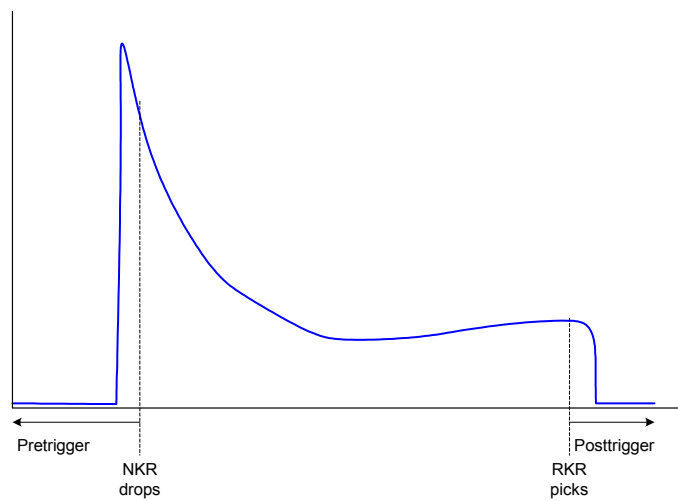

In the above diagram, the TX has been set to capture an N-R point move. It starts acquiring when the NKR drops, and finishes when the RKR picks.

Note that in this installation the NKR drops after the points begin to move and the RKR picks before then points cease movement. Hence a small amount of pretrigger and posttrigger is necessary to catch the motor current in its entirety.

**Setting up captures using the touchscreen**

Navigate to: [Menu..Configuration..Triggered captures](#)

The list of captures is shown. At first this will be empty.

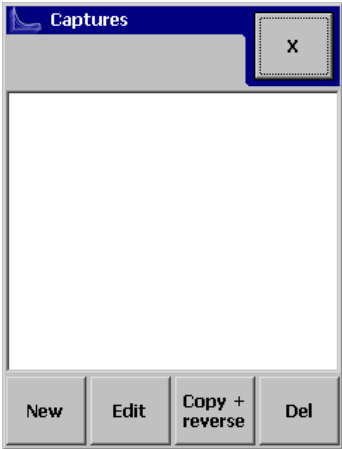

Press "New".

Type the name of the new capture (eg 786 N-R) and press "Enter".

The "Edit capture" dialog is shown.



Press the "Edit.." button next to Start Trigger.

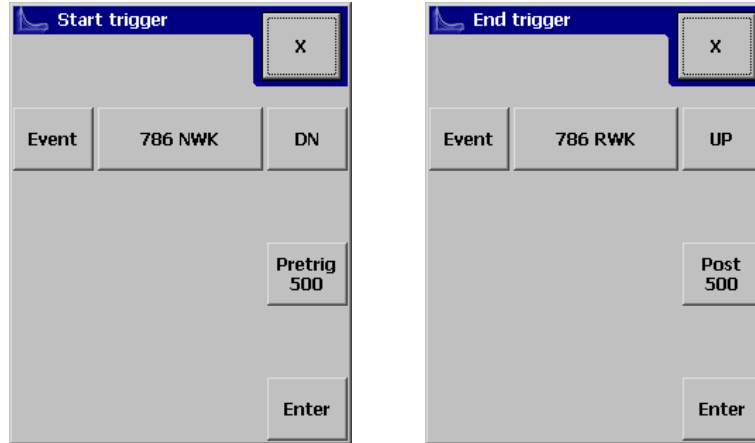

The top three buttons are toggle / cycle buttons. Pressing them repeatedly cycles through the types of trigger, channels and up/down. For more details on how this dialog works, see ["Trigger settings in detail"](#) later in this document.

Press "Enter" when you are happy with the trigger settings.

Do the same for the end trigger (see above right).

Now set the channels to log by pressing the "Edit" button next to "Logged channels".

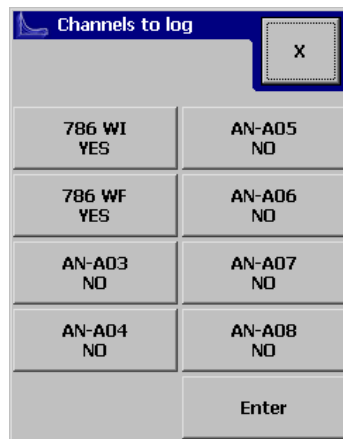

Pressing each of the buttons toggles between "Yes" and "No". Press "Enter" to go back to the Edit Captures dialog.

## Remote configuration

Finally press “Capture Group” to assign this capture to a “group”.

All captures within the same group will appear as a single asset on your central monitoring server, hence it is important that Normal to Reverse, and Reverse to Normal captures from the same end of points both belong to the same capture group.

| Edit capture                       |                 | X    |
|------------------------------------|-----------------|------|
| 786 N-R                            |                 |      |
| <b>Start trigger</b>               |                 |      |
| 786 NwK Dn<br>Pre:500ms Post:500ms | Edit...         |      |
| <b>Stop trigger</b>                |                 |      |
| 786 RwK Up<br>Pre:500ms Post:500ms | Edit...         |      |
| <b>Logged channels</b>             |                 |      |
| 786 W1<br>786 WF                   | Edit...         |      |
| Edit name                          | Capture Group 1 | Save |

All the capture details have now been entered.

To save these details, press the “Save” button. This saves the changes and immediately sets the capture up in the logger. If you press the “X” button at this point, the changes you have made will be discarded.

| Captures |      | X              |     |
|----------|------|----------------|-----|
| 786 N-R  |      |                |     |
|          |      |                |     |
| New      | Edit | Copy + reverse | Del |

The N-R capture has now been set up successfully.

Depending on the start and end trigger settings, creating the R-N capture can be as simple as selecting the 786 N-R capture as shown, and press "Copy + reverse".

The logger creates a new capture as follows:

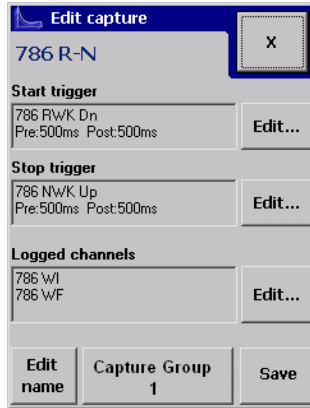

**NB** If the Copy and Reverse wizard does not find "N-R" on the end of the capture name, it will just add "Rev" to the end of it. For instance, "786 Nml-Rvs" will become "786 Nml-Rvs Rev". Hence it is good practice to stick to the naming conventions. Copy and Reverse will also not work if the two captures are not logically opposite of each other.

**If the start and end triggers are not logical opposites of one another, then the triggers will be incorrectly inverted. It is best practice to double-check the settings as manual adjustments are often necessary.**

Press "Save" to store this new capture.

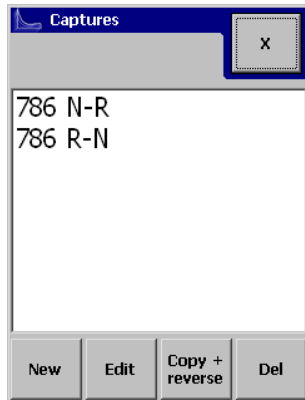

Both captures have now been set up successfully.

### Trigger settings in detail

The TX can be set to trigger on digital events or analogue threshold levels. The thresholds or events can be from any of the input channels – they don't need to be from the channels that are being logged.

By default the trigger will be an event trigger, digital channel 1, going DN.

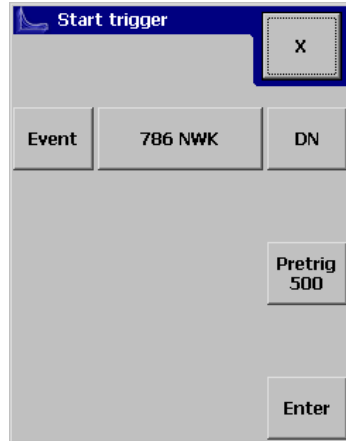

Pressing the button currently marked “786 NWK” will cycle through the digital channels.

Pressing “DN” will change the direction of the action to “UP”.

Pressing “Pretrig” and “Post[trig]” opens dialogs allowing the pretrig/posttrig values to be entered. These values are in milliseconds.

Pressing the “Event” button will change the type of trigger to a threshold level trigger (see over)

A keypad and a "level" textbox appears.



The screenshot shows a window titled "Start trigger" with a blue header. Below the header is a "Level" input field containing "1.5" and "A". To the right is a close button labeled "X". Below the input field is a keypad with the following layout:

| Level | 786 WI |   | More than   |
|-------|--------|---|-------------|
| 1     | 2      | 3 | Del         |
| 4     | 5      | 6 | Pretrig 500 |
| 7     | 8      | 9 |             |
| -     | 0      | . | Enter       |

The threshold can be set by entering a value on the keypad.

Pressing the button currently marked "786 WI" cycles through the analogue channels.

Pressing "More than" changes the direction of the trigger to "Less than".

## Remote configuration

Captures and acquire-on-change can also be set up remotely. The SA380TX implements SOAP entry points to allow this.

The URL is `http://<logger IP address>/cfg`.

This section of the manual only describes a couple of examples. A complete schema showing all the possible parameters and ranges is available – please contact MPEC if you require this.

### Examples

Consider a logger with channels set up as follows (note that all numbering of channels is zero-based in these messages).

#### Analogue channels

|       |         |                           |
|-------|---------|---------------------------|
| aip 0 | 771A WI | 771A Points motor current |
| aip 1 | 771A WF | 771A Points force         |
| aip 2 | 422TI   | 422 Track circuit current |
| aip 3 | 425TI   | 425 Track circuit current |
| aip 4 | ...     | ...                       |

#### Digital channels

|       |          |                       |
|-------|----------|-----------------------|
| dip 0 | 771 NWKR | 771 Normal detection  |
| dip 1 | 771 RWKR | 771 Reverse detection |
| dip 2 | ...      | ...                   |

The examples below show SOAP messages which set up the captures for 771A points, and the acquire-on-change for 422 and 425 track circuits.

## Captures (points)

Two captures are required, one for Normal-Reverse and one for Reverse-Normal.

```
<?xml version="1.0" encoding="utf-8"?>
<soap:Envelope xmlns:soap="http://schemas.xmlsoap.org/soap/envelope/"
xmlns:xsi="http://www.w3.org/2001/XMLSchema-instance"
xmlns:s="http://www.w3.org/2001/XMLSchema"
xmlns:txc="http://mpec.co.uk/sch/txc" >
  <soap:Body>
    <txc:setCfgCapturesRequest>
      <captures>
        <capt id="0" f="771A N-R" ena="1" push="1">
          <startTrig typ="ev" ch="0" a="0" t="500"/>
          <stopTrig typ="ev" ch="1" a="1" t="500"/>
          <logChans>
            <aipNo>0</aipNo>
            <aipNo>1</aipNo>
          </logChans>
        </capt>
        <capt id="1" f="771A R-N" ena="1" push="1">
          <startTrig typ="ev" ch="1" a="0" t="500"/>
          <stopTrig typ="ev" ch="0" a="1" t="500"/>
          <logChans>
            <aipNo>0</aipNo>
            <aipNo>1</aipNo>
          </logChans>
        </capt>
      </captures>
    </txc:setCfgCapturesRequest>
  </soap:Body>
</soap:Envelope>
```

Taking the first capture as an example, this tells the logger to:

- Set capture id 0 with a name of "771A N-R", enable it, and push data to the central system.
- Start to capture data 500ms before digital channel 0 goes Down.
- Stop capturing data 500ms after digital channel 1 goes Up.
- Capture the data from analogue channels 0 and 1.

## Threshold level triggers

The above example is for event triggers. To set a trigger for an analogue threshold level, use the following:

```
<startTrig typ="thr" ch="5" lvl="3.2" a="1" t="500" />
```

This trigger would operate when analogue channel 5 goes above a value of 3.2.

## Acquire-on-change (track circuits)

Acquire-on-change is simpler to set up. There is one acquire-on-change routine for each analogue channel.

The SOAP call is `<txc:setCfgAcqChgRequest>`. The following SOAP message sets up two acquire-on-change routines, one for each of the track circuits.

```
<?xml version="1.0" encoding="utf-8"?>
<soap:Envelope xmlns:soap="http://schemas.xmlsoap.org/soap/envelope/"
xmlns:xsi="http://www.w3.org/2001/XMLSchema-instance"
xmlns:s="http://www.w3.org/2001/XMLSchema"
xmlns:txc="http://mpec.co.uk/sch/txc">
  <soap:Body>
    <txc:setCfgAcqChgRequest>
      <acqChgs>
        <acqChg aipNo="2" ena="1" push="1" chg="2.5" n="100" t="2" />
        <acqChg aipNo="3" ena="1" push="1" chg="4" n="100" t="2" />
      </acqChgs>
    </txc:setCfgAcqChgRequest>
  </soap:Body>
</soap:Envelope>
```

Taking the first as an example, this tells the logger to:

- Set acquire-on-change on analogue channel 2, enable it, push data to the central system, acquire whenever the value changes by 2.5% of full scale, package acquired samples if there are no more samples acquired after 2 seconds or if there are 100 acquired samples waiting to be sent.

Note that acquire-on-change works on a percentage of full scale deflection. Hence if the full scale of the input is 600mA, 2.5% of this is 15mA, and so the logger will acquire a sample if the input changes by more than 15mA.

## SetCfgResponse

The response from the logger to both the captures and acquire-on-change messages is as follows:

```
<?xml version="1.0" encoding="utf-8"?>
<soap:Envelope xmlns:soap="http://schemas.xmlsoap.org/soap/envelope/"
xmlns:xsi="http://www.w3.org/2001/XMLSchema-instance"
xmlns:s="http://www.w3.org/2001/XMLSchema"
xmlns:txc="http://mpec.co.uk/sch/txc" >
  <soap:Body>
    <txc:setCfgResponse />
  </soap:Body>
</soap:Envelope>
```

This is a very simple empty response. Any errors in setting the config are returned as SOAP faults. If there is no SOAP fault, then the command completed OK.

## Getting configuration from the logger

To get a list of all the captures in the logger, send the following message:

```
<?xml version="1.0" encoding="utf-8"?>
<soap:Envelope xmlns:soap="http://schemas.xmlsoap.org/soap/envelope/"
xmlns:xsi="http://www.w3.org/2001/XMLSchema-instance"
xmlns:s="http://www.w3.org/2001/XMLSchema"
xmlns:txc="http://mpec.co.uk/sch/txc">
  <soap:Body>
    <txc:getCfgCapturesRequest />
  </soap:Body>
</soap:Envelope>
```

To retrieve a list of all the acquire-on-change settings, send the same message as above but with a SOAP call of `<txc:getCfgAcqChgRequest />`.



# Local access

This section describes how to use the touchscreen to configure the logger and access data.

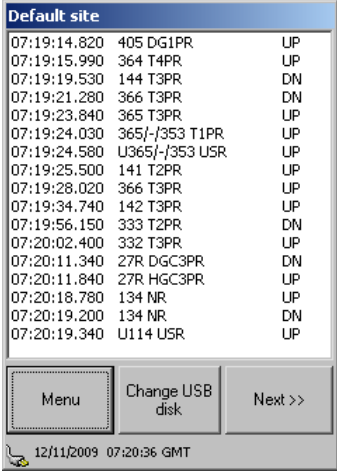
In normal operation, the touchscreen shows real-time input changes.



A mains / battery icon is shown at the bottom left of the screen. This has the following states:

-  Mains power connected
-  Mains power disconnected – running on battery

## How to view stored data

Press the "Menu" button. The following screen is displayed.

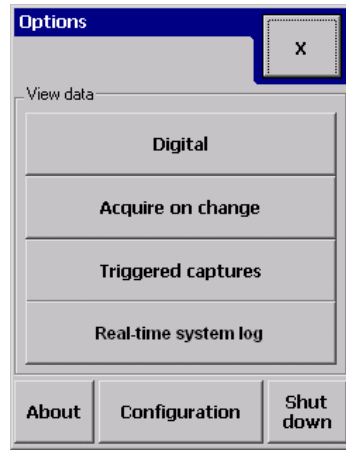

Press the "Digital" button.

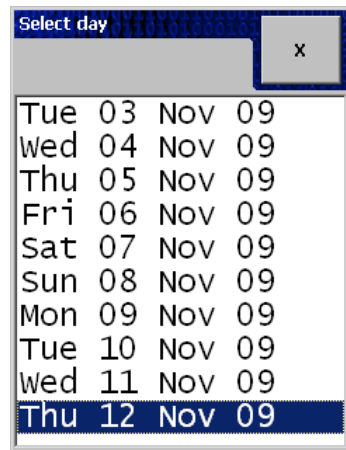

This screen shows all the days of data currently stored on the logger. Selecting one of the days brings up the following screen:

## Local access

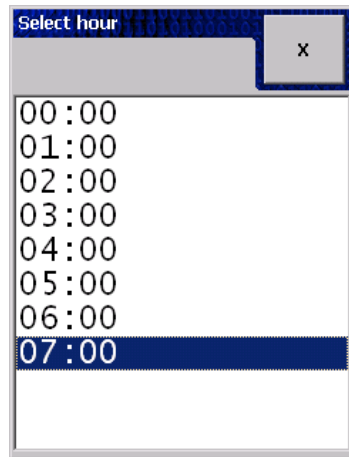

All files currently available for the selected day are shown.  
Selecting one of the hour files brings up the following screen:

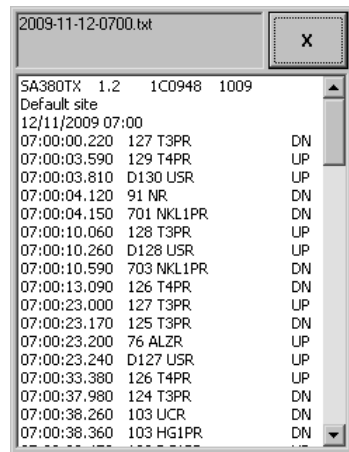

Use the scrollbar buttons to scroll up and down the data. You may need a tool to do this as the buttons are small. Avoid using sharp objects such as screwdriver blades or the point of a pen as these will damage the touchscreen. The back of a pen is ideal.

Use the same procedure to view detailed acquire-on-change and triggered capture data.

The real-time system log records useful diagnostic information about the state of the datalogger itself.

## How to change an external USB disk

You can insert a new USB disk at any time. The logger will beep twice to acknowledge the new disk and begin logging to it immediately.

However, before removing a disk you must follow these instructions.

**Important: Removing a USB disk without following these instructions can result in corrupt data and system instability.** This is because the logger may be in the middle of writing to the disk when you remove it.

On the main screen, press "Change USB disk".

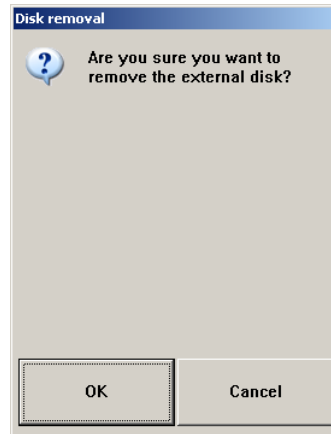

Press "OK". The following screen will be displayed:

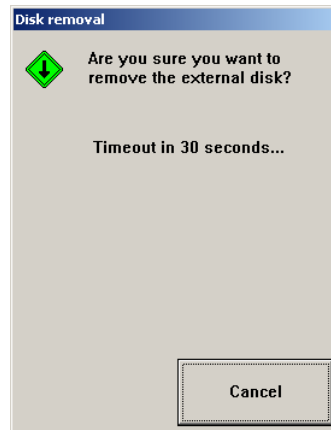

## Local access

Remove the disk. The logger will prompt you to insert a new one.

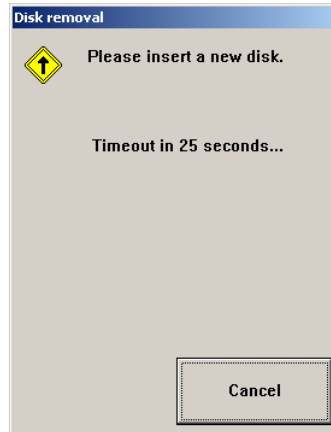

When a new disk is inserted, the logger should beep twice and return to the Real Time Events screen.

If you do not insert a new disk, the SA380TX will carry on logging to its internal disk.

## How to set the system date and time

Navigate to:

[Menu..Configuration \[enter security code\]..Set Date](#)

| Set date                                |   |   |       |
|---|---|---|-------|
| Date (dd/mm/yyyy)                       |   |   | X     |
| <input type="text" value="12/11/2004"/> |   |   |       |
| Time (hh:mm:ss)                         |   |   |       |
| <input type="text" value="05:10:36"/>   |   |   |       |
| 1                                       | 2 | 3 | Del   |
| 4                                       | 5 | 6 | Next  |
| 7                                       | 8 | 9 |       |
| -                                       | 0 | . | Enter |

Fill in the correct date and time and press Enter. "/" and ":" characters are entered automatically as you type. Note that the year must be entered in full (eg 2009).

## How to change the IP address

Navigate to:

[Menu..Configuration \[enter security code\]..Advanced config..Ethernet IP](#)

| Set IP address  |               |   |        |
|-----------------|---------------|---|--------|
| IP address      | 10.0.1.1      |   |        |
| Subnet mask     | 255.255.252.0 |   |        |
| Default gateway | 10.0.0.138    |   |        |
| 1               | 2             | 3 | Delete |
| 4               | 5             | 6 | Exit   |
| 7               | 8             | 9 | DHCP   |
|                 | 0             | . | Enter  |

Press the Delete button to delete the existing address and use the keypad to enter a new one.

### Some notes about IP addresses

The two important addresses are the IP address and the subnet mask. In order to get the logger to work correctly on a network:

- The subnet mask must be the same as the other computers on the network
- The IP address must be unique, ie it must be different to all other computers on the network.

The gateway should be set to the gateway on the subnet. Your system administrator will be able to provide this. If the logger is not on a network (ie it is only being used for direct cable connection), just leave the gateway set to 10.0.0.138.

See also "Direct cable connection" on page 51.

## How to set the local pass code

**NB** Be careful when changing this. If the pass code is forgotten, the logger can only be unlocked by the manufacturer.

Navigate to:

[Menu..Configuration \[enter security code\]..Advanced config..Set passcode](#)

| Set passcode                       |   |   |        | X |
|------------------------------------|---|---|--------|---|
| <input type="text" value="xxxxx"/> |   |   |        |   |
| 1                                  | 2 | 3 | Delete |   |
| 4                                  | 5 | 6 |        |   |
| 7                                  | 8 | 9 |        |   |
|                                    | 0 |   | Enter  |   |

| Repeat new code                    |   |   |        | X |
|------------------------------------|---|---|--------|---|
| <input type="text" value="xxxxx"/> |   |   |        |   |
| 1                                  | 2 | 3 | Delete |   |
| 4                                  | 5 | 6 |        |   |
| 7                                  | 8 | 9 |        |   |
|                                    | 0 |   | Enter  |   |

Enter a new five-digit pass code in the Passcode box, then repeat it in the Confirm box. Pressing Enter changes the code permanently.

## How to shut the logger down safely

Press Menu and then “Shut Down”. The following dialog is displayed.

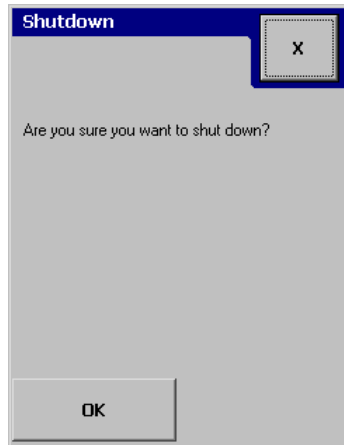

Press OK. The following dialog boxes will be displayed.



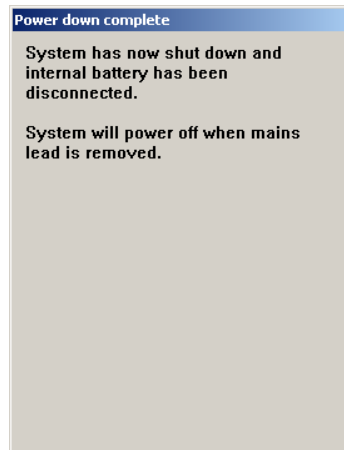

Once this dialog is displayed, remove the mains lead to power down the system.

## Hard reset shutdown

**NB this can result in system instability and corruption of data and should only be used as a last resort.**

If all else fails, the logger can be shut down by removing the mains cable and pressing reset. The reset button is behind a small hole on the base of the unit next to the Ethernet port. Use a paperclip or similar metal object to press the button.

## Network access

Three methods of access are provided:

- Direct cable connection for local access using a laptop
- Internet / intranet
- Dial-up

### Direct cable connection

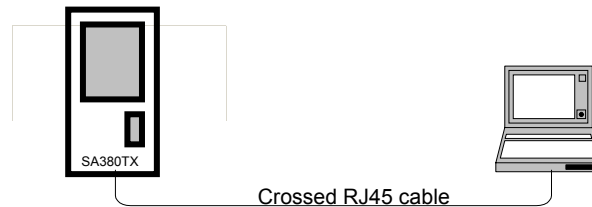

- Connect the logger to a computer using a crossed RJ45 network cable. If a crossed network cable is not available, two 'normal' RJ45 cables and a hub can be used
- Wait approximately 60 seconds for the logger to assign an IP address to your computer.
- Start Internet Explorer on the computer and enter the logger's IP address (eg <http://10.0.1.1:8080/>)

The SA380TX is factory-set with a fixed IP address of 10.0.1.1:8080. This address can be changed – see page 40 for details. Note that the web server is on port 8080.

See page 51 for troubleshooting of direct cable connections.

### Internet / intranet

If the logger is connected to a company network, its IP address will have been set when the unit was commissioned. To access the logger, type the address into your browser eg. <http://138.60.225.10>

## Dial-up

The following instructions apply to Windows 2000 / XP.

To connect to a logger over the phone network, a new Dial-up Networking connection must be created. To accomplish this, carry out the following steps.

### Go to Start Menu - Settings

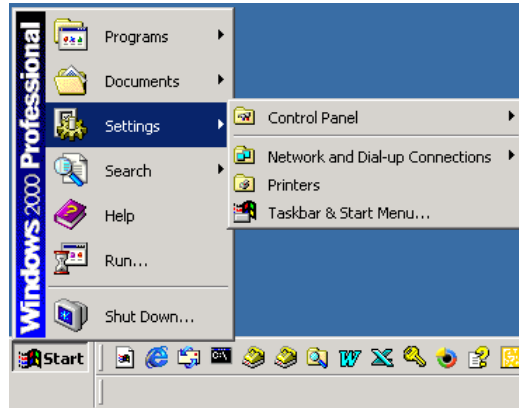

### Select Network and Dial-up Connections

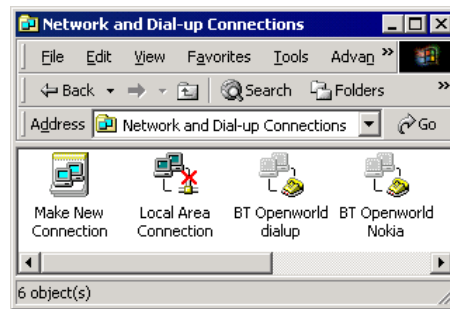

### Double-click on 'Make New Connection'



Click 'Next'

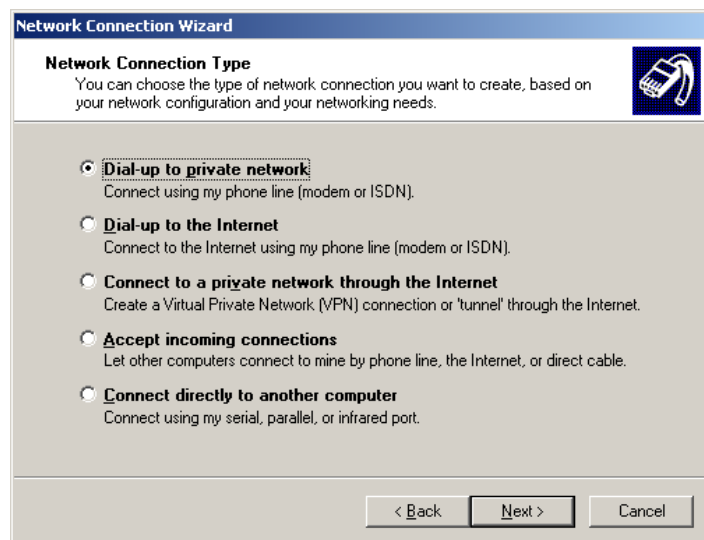

Select 'Dial-up to private network' and click 'Next'

## Network access

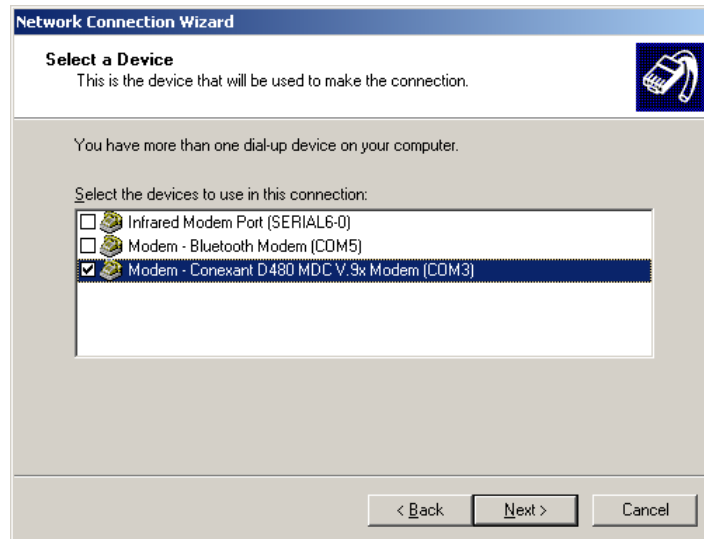

If you have more than one modem, select the one you wish to use and click "Next"

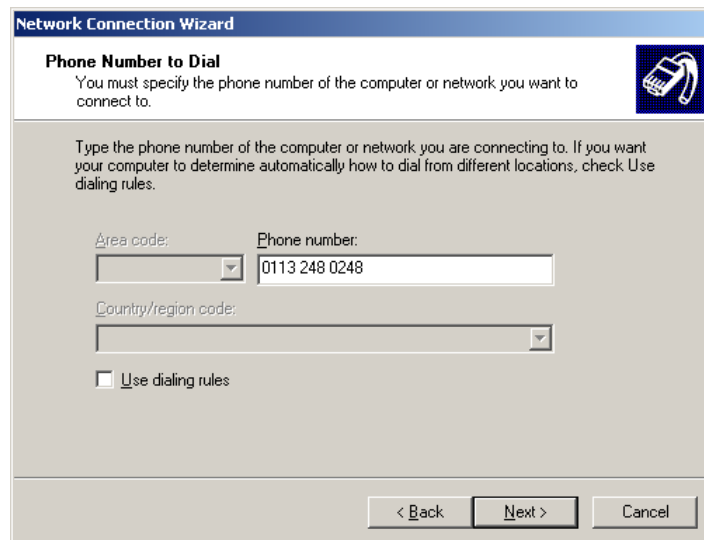

Enter the phone number of the remote logger and click 'Next'

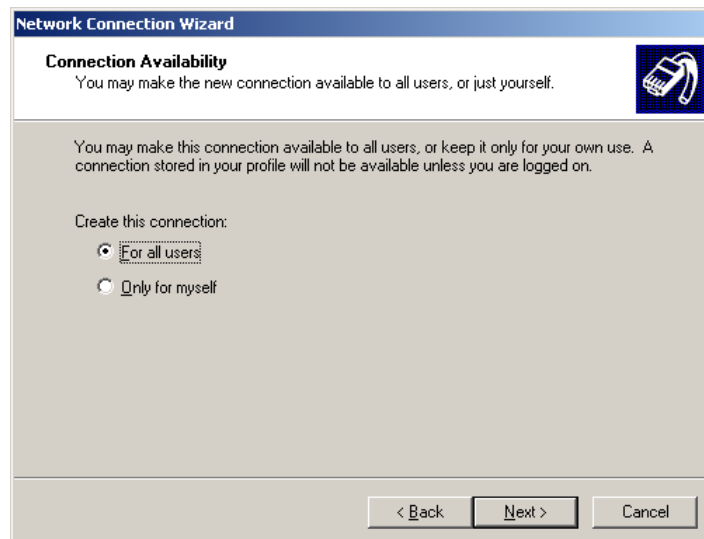

Click "Next"



Enter the name of the remote site. For ease of access you may want to tick the "Add a shortcut to my desktop" option. Click "Finish".

Windows then opens the dial-up dialog automatically.

## Network access

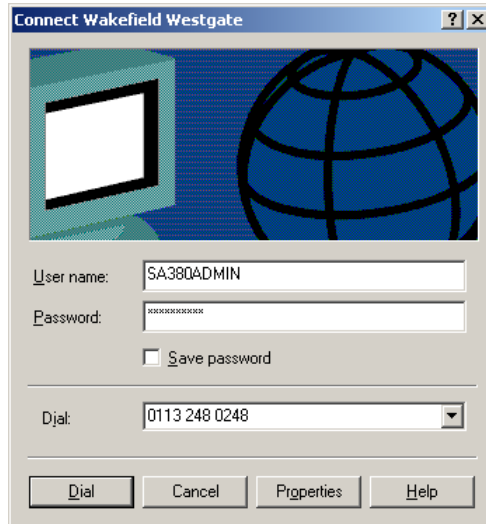

Enter the user name and password supplied with the logger and click "Dial". Windows will then attempt to connect to the remote logger as if it was an internet service provider.

Once the connection is made, launch Internet Explorer and enter the IP address "192.168.1.1:8080". The following should be shown:

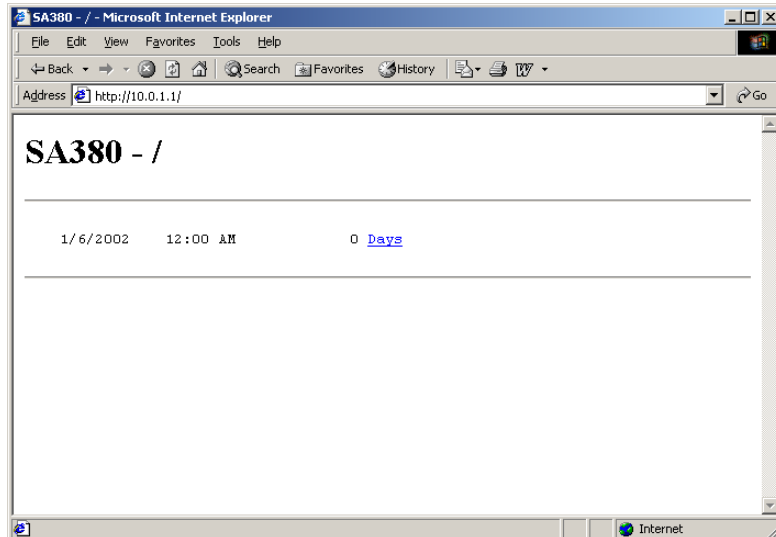

## Troubleshooting direct cable connections

If your computer is running Windows 2000 or XP, access to the SA380TX should be as simple as connecting an RJ45 crossover cable and typing <http://10.0.1.1:8080> into your internet browser.

However, networking between computers is often not as straightforward as it should be. The following steps should be followed if you are having difficulty connecting.

### Some notes about IP settings

The two important addresses are the IP address and the subnet mask. In order to get the logger to work correctly on a network:

- The subnet mask must be the same as the other computers on the network
- The IP address must be unique, ie it must be different to all other computers on the network.

For instance, the following settings will work:

| Equipment | IP address     | Subnet mask   |
|-----------|----------------|---------------|
| Laptop    | 138.168.254.65 | 255.255.254.0 |
| Logger    | 138.168.254.66 | 255.255.254.0 |

## Checking the network connection

This is accomplished using the TCP/IP Ping command.

Go to Start menu - Run...

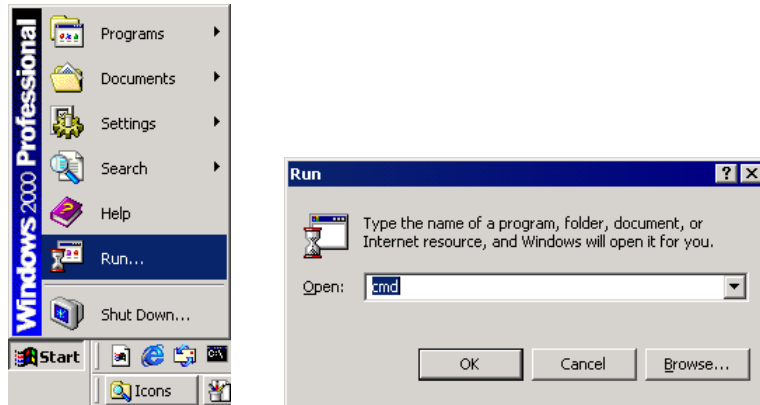

Enter 'cmd' and click 'OK'

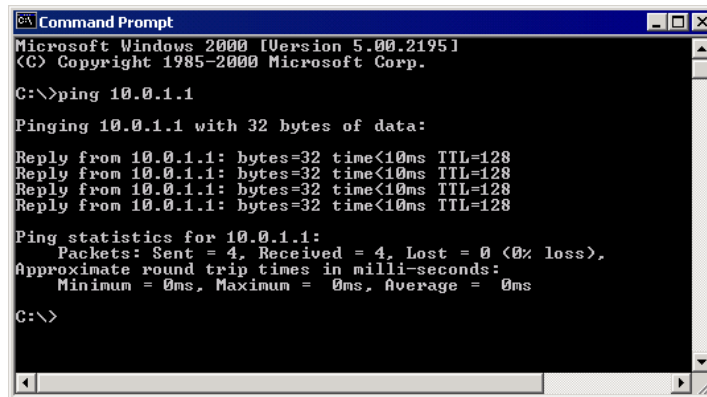

Type 'ping 10.0.1.1' (or whatever IP address you have chosen for the logger)

The response should be as shown above. This proves that the network cable is connected and wired correctly. It also proves that TCP/IP on both your computer and the SA380TX are installed, working and talking to each other.



## EbiTrack® Monitoring

### Wiring up EbiTrack Units for Monitoring

Up to six EbiTrack units may be monitored using a single SA380TX using a multidrop RS485 network. Configure the network as shown below using twisted pair cable. Note the use of termination resistors at each end of the link.

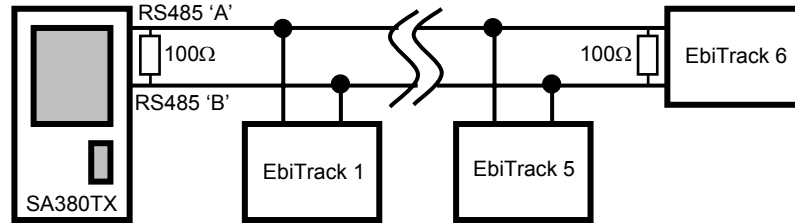

The EbiTrack units' RS485 interface utilises a 9-pin D-sub connector. The connector must be wired as follows:

- Pin 1: RS485 Mode Select (Connect to Pin 9)
- Pin 2: Signal Pair (Connect to RS485 line B)
- Pin 6: Signal Pair (Connect to RS485 line A)
- Pin 9: 5V DC (Connect to Pin 1)

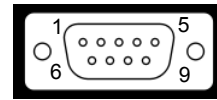

DE-9 Connector (Front)

### Setting Up a new EbiTrack Unit

Navigate to the EbiTrack overview screen by cycling through the various summary display screens:



Cycle to the EbiTrack overview screen by repeatedly pressing the menu cycle button...

The EbiTrack overview screen is shown below without any EbiTrack units configured. To configure a unit, first press upon one of the six squares.

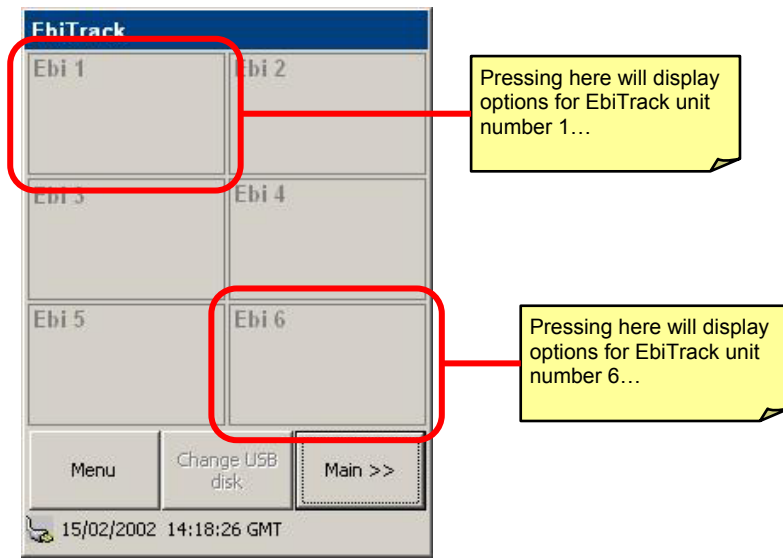

This will display the "Real-Time" data display for the selected EbiTrack unit. As the unit is not yet configured this display is blank. Press the configuration button.

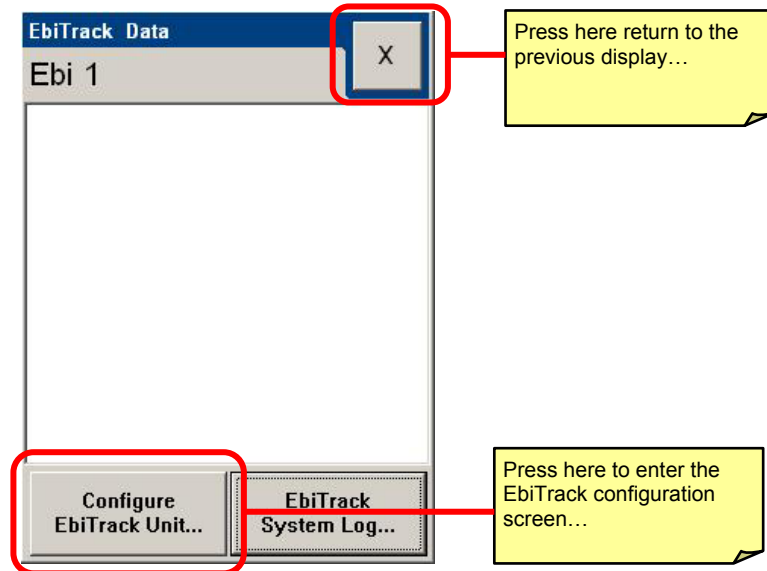

## EbiTrack Monitoring

You will be prompted to enter a password (see main user guide) before being permitted to view the EbiTrack configuration screen. Once the configuration screen is displayed, follow the data entry instructions below.

The screenshot shows the 'Edit EbiTrack Unit' configuration screen. The title bar is blue with the text 'Edit EbiTrack Unit'. The main area is light grey and contains several fields and buttons. A red box highlights the 'Track cct name' field with the value 'AA Tx' and the 'Key ID number' field with the value '456871'. Another red box highlights the 'Unit type' field with the value 'EBITrack 400 Tx' and the 'Push to server' field with the value 'ENABLED'. A third red box highlights the 'Save' button at the bottom. A fourth red box highlights the 'X' button in the top right corner. Callout boxes provide instructions for each of these elements.

Pressing here prompts you to enter the name of the unit you wish to monitor.  
Enter the name as it appears in your signalling installation...

Pressing here prompts you to enter the unique key serial number of your EbiTrack unit.  
This number is printed on the EbiTrack data key.

Press here to return to the previous display without saving configuration settings...

Pressing here toggles "Push to server" between "Enabled" and "Disabled".  
When "Enabled" the SA380TX will transmit real-time analogue data back to the server defined in the "Connection Profile" settings

Pressing here prompts you to select the model of EbiTrack unit you are monitoring from a pre-set list.  
This selection determines which parameters are displayed to the user and recorded in real-time.

Once all of the configuration information has been entered, press here to permanently save these settings.  
**Please note that saving settings can take several seconds.**

## Removing an Existing EbiTrack Unit

Navigate to the EbiTrack configuration screen of the EbiTrack unit you wish to remove by following the steps listed in **“Setting Up a New EbiTrack Unit”**. Once the configuration screen is displayed follow the instructions below.

The screenshot shows the 'Edit EbiTrack Unit' configuration screen. The title bar is blue with the text 'Edit EbiTrack Unit'. Below the title bar, there are several fields and buttons. A red box highlights the 'X' button in the top right corner. A red box highlights the 'Key ID number' field, which contains '0(OFF)'. A red box highlights the 'Save' button at the bottom. Three yellow callout boxes provide instructions for each highlighted element.

|                              |                           |
|------------------------------|---------------------------|
| Track cct name<br>AA Tx      | Key ID number<br>0(OFF)   |
| Unit type<br>EBITrack 400 Tx | Push to server<br>ENABLED |
| Save                         |                           |

Press here to return to the previous display without saving configuration settings...

Pressing here prompts you to enter the unique key serial number of your EbiTrack unit.  
Enter a Key ID of "0" (Zero) to disable or remove an EbiTrack unit.

Once all of the configuration information has been entered, press here to permanently save these settings.  
**Please note that saving settings can take several seconds.**

### Viewing Data on the Touch Screen

Navigate to the EbiTrack overview screen by cycling through the various summary display screens:

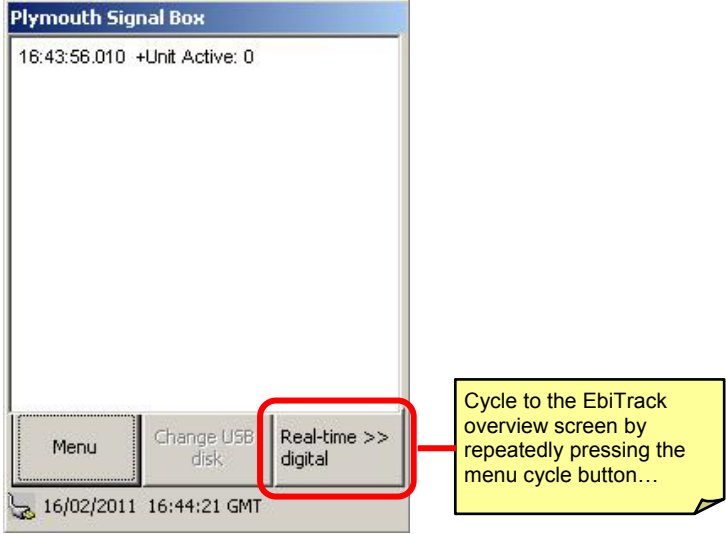

The EbiTrack overview screen displays important parameters of monitored EbiTrack units at a glance.

The screenshot shows the EbiTrack overview screen with several unit status cards. The 'AA Tx' card is highlighted with a red background. Other cards show parameters for 'BE Rx', 'AA Rx', and 'CD Rx'. A 'Main >>' button is located at the bottom right of the screen.

**AA Tx** (Red background)

**BE Rx**  
Iusb: 102mA  
Ilsb: 103mA  
Ith: 90 mA  
Relay: 1

**AA Rx**  
Iave: 89mA  
Qual: 100  
Ith: 120mA  
Relay: 0

**CD Rx**  
Iusb: 16mA  
Ilsb: 16mA  
Ith: 94mA  
Relay: 0

**Ebi 5**

Menu    Change USB disk    Main >>

15/02/2002 14:18:26 GMT

A red background indicates a communications problem with this unit. Either RS485 comms are down or the unit is unresponsive.

Important parameters of configured EbiTrack units are available at a glance.  
Press here to view more detailed information about this unit...

This unit has not been configured.

Pressing on a configured EbiTrack Unit will show the "real-time" data display for that unit. This screen shows many more operational parameters of the EbiTrack Unit.

The screenshot shows the 'EbiTrack Data' screen for unit 'AA Tx'. It lists various operational parameters. A scroll bar is on the right. Buttons for 'Configure EbiTrack Unit...' and 'EbiTrack System Log...' are at the bottom.

**EbiTrack Data**

**AA Tx**

Trans Temp 35C  
FET Temp 41C  
Vpsu 48.5V  
V drive 35.3V  
I drive 31mA  
P drive 1W  
Status 0x0C80  
Freq Code 1699  
FPGA Stat 0x93FF  
Key ID 70

Configure EbiTrack Unit...    EbiTrack System Log...

Press here to return to the previous display...

Scroll up and down to view all parameters...

Press here to access daily system log files...  
**Due to the length of these files it is recommended that they be viewed remotely. (see next section)**

## Viewing Data Remotely

Data files can be viewed remotely from the SA380TX by either establishing a network connection to the SA380TX, or retrieving data files using a USB memory disk device. Both practices are detailed in the main user guide.

EbiTrack data is to be found within each of the “day” folders of the SA380TX file system. The system log messages can be found in the root folder for each day.

### SA380 - /Days/20110217/

[\[To Parent Directory\]](#)

|         |          |   |
|---------|----------|---|
| 2/17/11 | 12:00 AM | <a href="#">18198 20110217Log.txt</a>     |
| 2/17/11 | 12:00 AM | <a href="#">3612 20110217EBTLog03.txt</a> |
| 2/17/11 | 12:00 AM | <a href="#">3848 20110217EBTLog02.txt</a> |
| 2/17/11 | 12:00 AM | <a href="#">4187 20110217EBTLog01.txt</a> |
| 2/17/11 | 12:00 AM | <a href="#">0 acqchg</a>                  |
| 2/17/11 | 12:00 AM | <a href="#">2744 2011-02-17-1400.txt</a>  |
| 2/17/11 | 12:00 AM | <a href="#">1472 2011-02-17-1500.txt</a>  |
| 2/17/11 | 12:00 AM | <a href="#">0 cfgchg</a>                  |

Analogue data is to be found within the “acqchg” folder found in each “day” folder. Each analogue data channel for each EbiTrack unit has a separate file.

### SA380 - /Days/20110217/acqchg/

[\[To Parent Directory\]](#)

|         |          |  |
|---------|----------|--|
| 2/17/11 | 12:00 AM | <a href="#">1450 2011-02-17 08 02 VPSU AA (TX).txt</a> |
| 2/17/11 | 12:00 AM | <a href="#">1450 2011-02-17 09 02 LERC AA (TX).txt</a> |
| 2/17/11 | 12:00 AM | <a href="#">1450 2011-02-17 10 02 VOPD AA (TX).txt</a> |
| 2/17/11 | 12:00 AM | <a href="#">1450 2011-02-17 11 02 POPD AA (TX).txt</a> |
| 2/17/11 | 12:00 AM | <a href="#">1650 2011-02-17 12 02 IOPD AA (TX).txt</a> |
| 2/17/11 | 12:00 AM | <a href="#">1450 2011-02-17 13 02 TFET AA (TX).txt</a> |
| 2/17/11 | 12:00 AM | <a href="#">1450 2011-02-17 14 02 TTRN AA (TX).txt</a> |
| 2/17/11 | 12:00 AM | <a href="#">1450 2011-02-17 15 02 ADIF AA (TX).txt</a> |

# Specifications

## Default MIMOSA parameter offsets

| Parameter       | Type  | Offset | Control or Measurement | Read / write access |
|-----------------|-------|--------|------------------------|---------------------|
| Heartbeat<br>xx | DAInt | 6      | M                      | R                   |

[\*\*\*The above table needs filling in ]

## Technical specifications

### General

|                          |                                     |
|--------------------------|-------------------------------------|
| Digital inputs per unit  | 10, 18 or 26                        |
| Analogue inputs per unit | 0, 4 or 8                           |
| Fixings                  | To fit standard BR930 relay rack    |
| Size                     | 135 x 56 x 175mm - 1 relay position |
| Processor                | 520MHz                              |
| RAM                      | 64Mb                                |
| Internal flash storage   | 512Mb                               |

### Communications

|                |                        |
|----------------|------------------------|
| Ethernet       | 10baseT / 100baseTX    |
| Internal modem | GSM/GPRS               |
| RS485          |                        |
| Protocols      | TCP/IP, UDP, PPP, HTTP |

### Digital inputs

|                             |                               |
|-----------------------------|-------------------------------|
| Type                        | Volt-free relay contacts      |
| Isolation to earth          | 10M $\Omega$ at 1,000V DC min |
| Max differential DC voltage | 55V                           |

### Analogue inputs

|                    |                               |
|--------------------|-------------------------------|
| Range              | 4-20mA / 0-30V                |
| Resolution         | 10 bit                        |
| Sampling rate      | 500Hz / RMS 5 samples         |
| Isolation to earth | 10M $\Omega$ at 1,000V DC min |

### Power supply

|                                |                               |
|--------------------------------|-------------------------------|
| Power supply                   | 90-264Vac                     |
| Isolation to earth             | 10M $\Omega$ at 1,000V DC min |
| Power consumption no inputs    | 3W                            |
| Power consumption absolute max | 40W (0.37A at 110V)           |
| Internal UPS                   | 7.2Wh                         |
| Full recharge time             | 24 hours                      |

[blank page]